

escoView eTOP19CP

DRAFT

Instruction manual

Summary

Technical Data.....	3
CE and Marine certification.....	4
Usage and Safety Guidelines	4
Applicable Regulations	4
Installation Environment	5
Cut out and Front view:.....	5
Applying the gasket and fixing the pannel :	5
Cleaning Faceplates	5
Power supply and grounding	6
Network connections	6
Can J 1939 Network connection:.....	7
Example of connection cable for J 1939 network :	7
LED Status.....	9
Battery protection and replacement.....	9
Getting Started.....	11
Command Summary.....	12
Operation mode	12
Configuration Mode.....	12
Command Menu	12
Troubleshooting	13
Touchscreen Calibration.....	13
Standard calibration:.....	13
Emergency calibration.	13

escoView eTOP19CP

Technical specifications

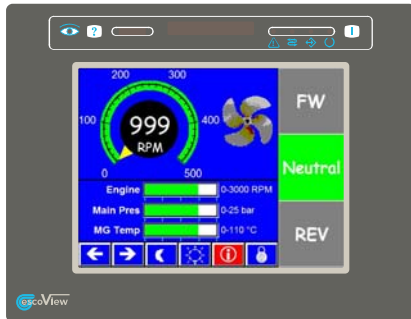

The eTOP19CP is a state-of-the-art HMI device featuring a high-brightness sunlight-readable 5.6" TFT colour display with ¼ SVGA (320x240) resolution and resistive touch screen.

This product has been specifically designed for use under extreme illumination conditions.

Support for 64K colours in the brilliant TFT display will increase the realism of the images.

Connectivity is ensured by the integrated 10/100 Ethernet interface and the dual-module option.

The coated electronics and the extended operating temperature range make this product ideal for applications in harsh environments.

Technical Data

Display Type Resolution Active display area Colours Backlight Brightness Dimming	5.6 " TFT ¼ VGA, 320x240 pixel 121x91 mm (5.6"diagonal) 64K CCFL, 25000 h (note 1) 500 cd/m2typ. Yes
Memory User memory Alternate User memory	64 MB internal Flash Optional removable 32/64 MB SSFDC memory card
Front panel Touch screen Function/System keys User / System LED's	Analogue resistive 1 / - 1 / 4
Interfaces PC/Printer port PLC port J1939 Can port Ethernet port Serial program. speed Slot for Local I/O USB port	Yes RS-232, RS-485, RS-422, Yes 10/100 Mbit 9600 – 38400 bps Yes Yes for program download
Ratings Power supply voltage Current consumption Fuse Weight	18 - 30 VDC Max 1.8 A at 24 VDC Automatic Approx 1.4 Kg
Approvals CE RINA Germanischer Lloyd	Emission EN 61000-6-4 Immunity EN 61000-6-2 for installation in industrial environments Type approval certificate for installation in naval environments

Environmental Conditions Operating temperature Storage temperature Operating and storage humidity Protection class	-10 to 55 °C (-10 to 45 °C with UIM05P) -20 to +70 °C 5 – 85 % RH non-condensing IP65 (front panel) IP20 (rear)
Dimensions Faceplate LxH Cut-out AxB Mounting depth	187x147 mm (7.36x5.79") 176x136 mm (6.93x5.35") 91 mm (3.58")
Functionality Vector graphics Dual driver capability Data acquisition and trends Recipe memory UniNet network Alarms Event list Password Hardware RTC Screen saver Buzzer Battery	Yes Yes Option 32 KB Client/Server 1024 1024 Yes Yes, battery backed Yes Yes, audible feedback for Touchscreen 3 V 270 mA Lithium, non rechargeable, user replaceable, model CR2430. Replace with same component or equivalent compatible with the operating temperature of the product.

Note 1: the lamp lifetime is the typical value for continuous operation at 25°C.

Note 2: a filter NEF 1-10 Phoenix Contact or equivalent must be installed to comply with emission limits for equipment installed in naval environments in the bridge and deck zone according to RINA / GL rules.

CE and Marine certification

The panel EscoView eTop 019 CP has been designed for installation in an industrial environ in compliance with the regulations:

- Emitted interference EN 61000-6-4
- Noise Immunity EN 61000-6-2

In compliance with the above regulations the products are CE marked.

For marine applications, this panel has been approved by Rina and Germanischer Lloyds



A filter NEF 1-10 Phoenix Contact or equivalent must be installed to comply with emission limits for equipment installed in naval environments in the bridge and deck zone according to RINA / GL rules.

Usage and Safety Guidelines

Applicable Regulations

Regulations and recommendations have been issued in Europe covering the main safety-related issues in control systems which include operator interfaces.

EN 60204-1 lists some important guidelines applicable when using operator interfaces.

- 9.2.4 Suspension of safeguards
- 9.2.5.3 Stop
- 9.2.5.4 Emergency stop
- 9.2.5.6 Hold-to-run controls
- 9.2.5.7 Two-hand controls
- 9.4 Control function in case of failure

Do not use operator interface to directly command motors, valves or other actuators not equipped with safeguards and potentially harmful to persons or equipment in case of fault to the unit.

The units are intended to be mounted on the front panel of a metallic cabinet. The service personnel, when operating directly on the powered unit, must be electrostatically discharged.

All safety related regulations must be observed

CAUTION! Don't open the panel rear cover when the power supply is applied.

Installation Environment

Cut out and Front view:

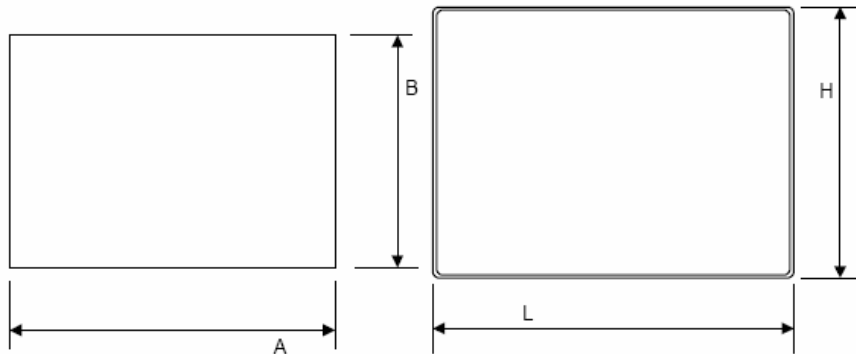

Cut out:
A = 176 mm
B = 136 mm

Front view:
L = 187 mm
H = 147 mm

Depth : 91 mm

The equipment is not intended for installation in contact with corrosive chemical compounds. Check the resistance of the front panel film to a specific compound before installation.

Do not use tools of any kind (screwdrivers, etc.) to operate the keyboard of the panel or the touch screen.

In order to meet the front panel protection classifications, proper installation procedure must be followed:

- The borders of the cut-out must be flat
- Screw up each fixing screw until the plastic bezel corner get in contact with the panel.
- The cut-out for the panel must be of the dimensions indicated in this manual.

Applying the gasket and fixing the panel :

- The gasket should be applied on the operator panel just behind the bezel
- The gasket should be replaced every time that the panel is dismantled and remounted in its place

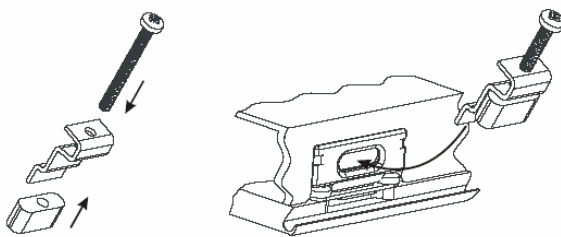

Place the four fixing brackets on the longer side near the corners, as shown in figure. Screw each fixing screw until the plastic or aluminium bezel corner get in contact with the panel.

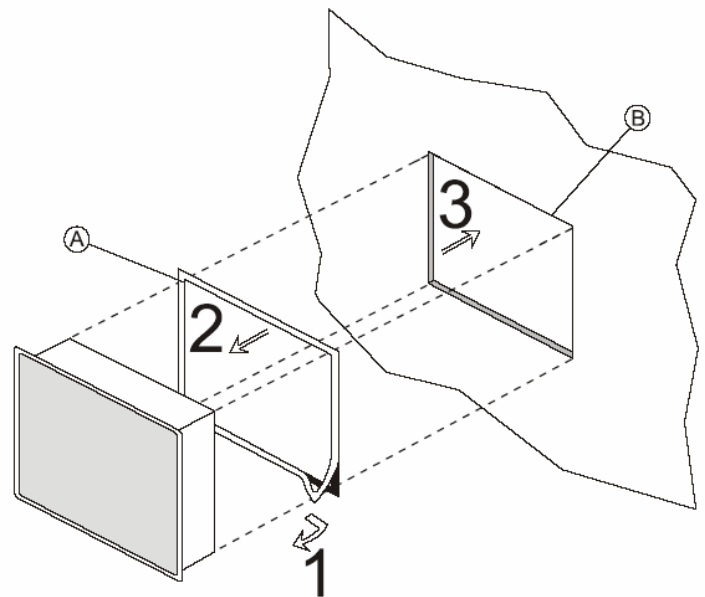

Cleaning Faceplates

The equipment must be cleaned only with a soft cloth and neutral soap product. Do not use solvents.

Power supply and grounding

- Voltage : 18 to 30 VDC
- Current : 1.8 A at 24 VDC
- No fuse in the device , protection by over-current electronic protection

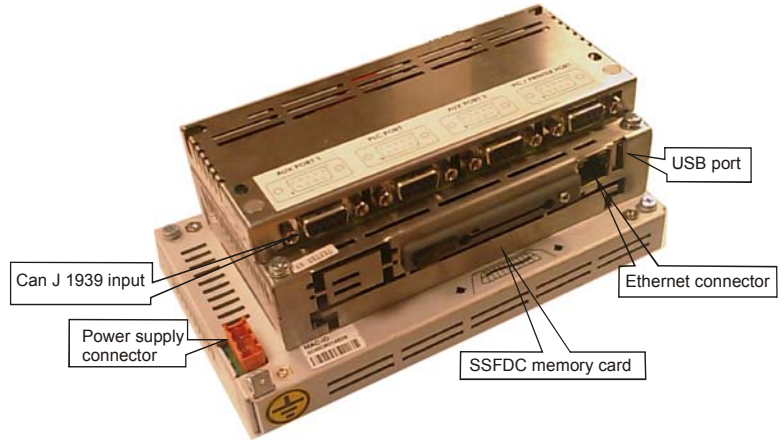
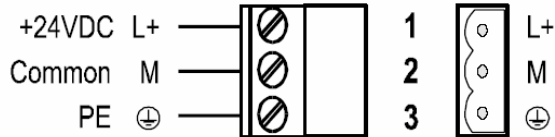

The power supply terminal block is shown in the figure left. The terminal block is included with the panel.

Note: ensure that the power supply has enough power capacity for the operation of the equipment. (1.8 A at 24 VDC)

The unit must always be grounded to protection earth (PE). Grounding helps limit the effects of noise due to electromagnetic interference on the control system. Earth connection will have to be done using either the screw or the faston terminal located near the power supply terminal block. A yellow label help identify the ground connection. Also connect to ground the terminal 3 on the power supply terminal block.

The power supply circuit may be floating or grounded. When using the floating power scheme, note that the panels internally connect the power common to ground with a 1 MΩ resistor in parallel with a 10 nF capacitor. The power supply must have double or reinforced insulation. All the electronic devices in the control system must be properly grounded. Grounding must be performed according to applicable regulations.

Network connections

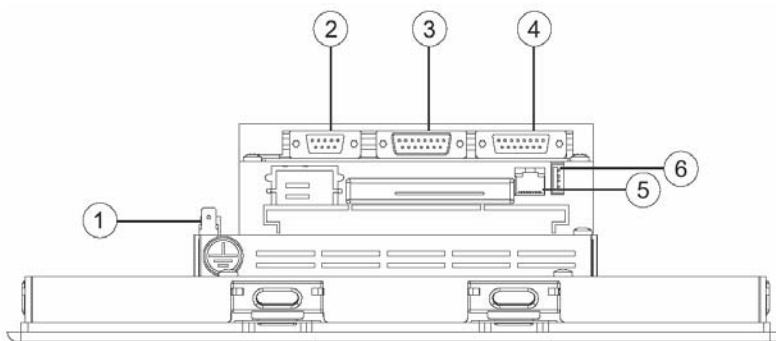

- 1 : Power connection and earth
- 2 : Db 9 Can J 1939 connection
- 3 : Rs 485 / 232 connection
- 4 : PC / printer port
- 5 : Ethernet port
- 6 : USB port

Note : for standard applications use only power supply connection and Db9 Can J 1939 connection.

Other connectors only for special applications please refer to factory for details

LED Status



LED			
Sign	Colour	State	Description
⚠	Red	OFF	No hardware problem ; backup battery OK
		Blink	Backup battery low
		ON	Hardware problem : consult factory
	Green	OFF	No keys are pressed
		ON	Key pressed (visual feedback)
⌚	Green	OFF	Hardware problem : consult factory
		ON	Unit in normal operation
⚡	Green	Blink	Communication error
		ON	Communication OK
⚠	Red	OFF	No Alarms
		Blink	Alarm requires acknowledgment
		ON	Active alarm

Battery protection and replacement

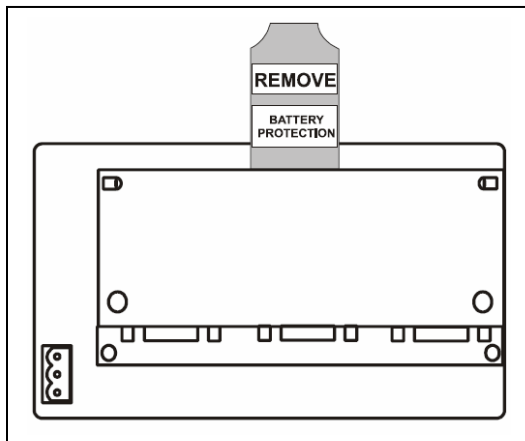

The panel EscoView eTop 019 CP s requires the use of the lithium battery for data back-up.

The following information is maintained by the battery:

- Hardware real-time clock (date and time)
- Event list
- Recipe data

Before operation of the panel remove the battery protection strip

The panel EscoView eTop 019 CP signal the battery status by blinking of the LED indicator ⚠

When the panel signals that the battery is low, you should replace the battery as soon as possible.

Note: Replacing the battery will cause the loss of the data maintained by the battery.

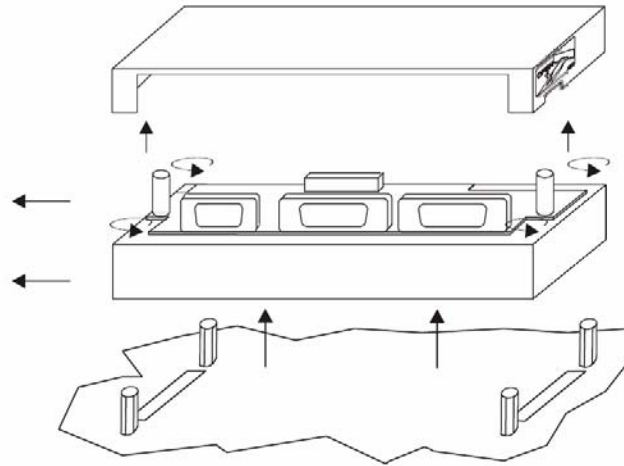
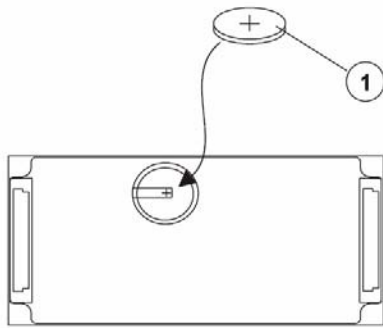

To replace the battery, follow the procedure listed below:

- 1) Turn off the power to the panel
- 2) Use a screwdriver to loose the four screws securing the block composed by the two metal units
- 3) Remove the block
- 4) Remove the battery
- 5) Replace the battery with a new one

6) Replace the block; tighten the four screws

7) Apply power to the panel and check that battery good status is signalled.

CAUTION! Danger of explosion if battery is incorrectly replaced .Replace only with the same or equivalent type recommended by the manufacturer. Dispose of used batteries according to the manufacturer's instructions.

Back-up battery information: 3 V 270mA Lithium, not rechargeable, life about 1 year, user replaceable, Model: CR2430.Change with same battery or equivalent with the work temperature of the panel

Getting Started

The panel EscoView eTop 019 CP is normally delivered with the Can J1939 interpreter and pre-programmed screens. When the panel is powered up, after a few seconds necessary to upload the boot the first screen appears.

Screens available with the standard package :

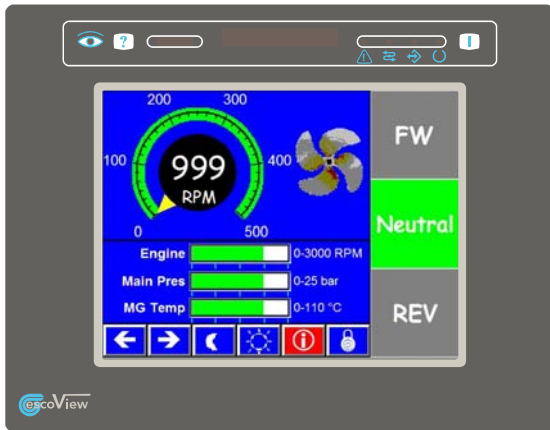

Propeller speed



Motor speed

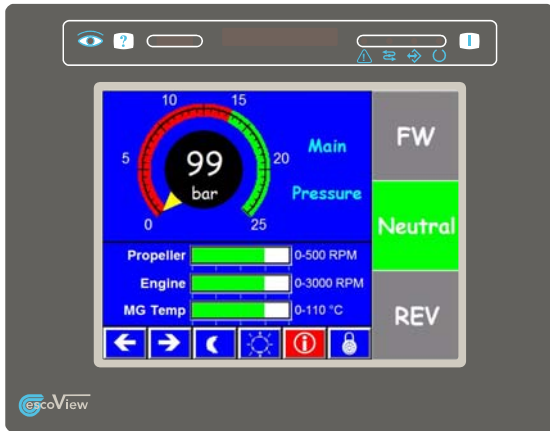

Transmissions pressure



Transmissions temperature

Will be completed later

Command Summary

This chapter describes the keyboard commands recognized by the panel. Commands are classified according to the operating modes of the unit. The panel will show system defined touch keys on the screen whenever it is required. The panel will show automatically a numeric keypad whenever the data entry phase is activated.

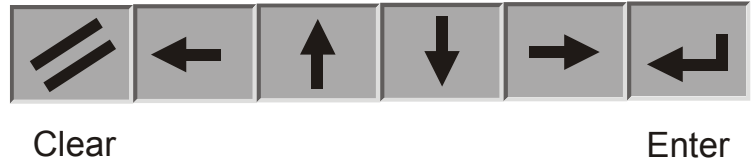

Note: the text '2 s' associated to a key means that the key has to be held for two seconds to activate the associated function.

Operation mode

This mode is the default mode when the panel is switched on. Normal operation of the application in the panel is performed







Configuration Mode

To call or recall the Configuration Mode, touch the screen in an area where no touch cells have been defined and hold for 2 seconds.







ENTER shows the type and version of the communication driver stored in the unit (if any)

ENTER "2 s" returns to Operation Mode if a valid communication driver and a valid project are stored in the unit (the key must be pressed for 2 seconds)

Command Menu

-  Select up
-  Select down
-  Select left
-  Select right
-  ENTER activate selection
-  CLEAR return to Page Mode

System Menu

-  Select up
-  Select down
-  Activate selection
-  Activate selection
-  ENTER return to Page Mode when EXT is selected
-  CLEAR return to Page Mode







Troubleshooting

In the case it might be impossible to switch the operator panel to Configuration Mode due to problems in the start-up phase, follow the procedure described below:

1. Switch off the unit
2. Touch in the middle of the left side of the display screen with the left hand
3. Switch on the operator panel and tap with the right hand in the middle of the right side of the display screen with a period of about one second.
4. Continue until the screen will show Configuration Mode

Touchscreen Calibration

Standard calibration:

1. Recall Configuration Mode
2. Touch the  key (clear) on the screen until a small round symbol will appear on the top right corner of the screen
3. Touch and hold the symbol until it will move to the low left corner of the screen
4. Touch and hold the symbol until the indication to touch the  key will be displayed on the screen
5. Touch and hold the key  until the indication to touch the  key will be displayed on the screen
6. Touch and hold the key  until the indication to touch the Enter key will be displayed on the screen
7. Touch and hold the  key until the panel will switch to Operation Mode (if a valid project is loaded in the memory)

Emergency calibration.

The Emergency calibration procedure should be used in all cases when it would result not possible to go to calibration using the standard procedure.

1. Switch of the unit
2. Turn on the unit
3. Tap in the middle of the touchscreen with a frequency of about one second until the operator panel will enter the Calibration Mode
4. Perform the standard calibration procedure.